

FAUQUIER COUNTY WATER AND SANITATION AUTHORITY
7172 KENNEDY ROAD • WARRENTON, VA 20187
PHONE (540) 349-2092 • FAX (540) 347-7689
www.fcwsa.org



HYDRANT METER PERMIT REQUEST

Application Date: _____
Applicant: _____
Billing Address: _____

Work/Daytime Phone: _____
Home/Evening Phone: _____
Email: _____
Hydrant Number(s) to Be Use: _____
Specific Purpose of Use: _____
Annual Return Date: _____

Check One:

I agree to have Fauquier County Water and Sanitation Authority (FCWSA) install hydrant meter at above location. I understand installation will be completed when freezing temperatures are not present for a three-day window.

I wish to install hydrant meter at above location(s). I agree to follow installation and operation procedures according to FCWSA Detail WM-05, Temporary Hydrant Meter Assembly.

Applicant has received, read and agrees to the Hydrant Meter Policy and all terms and conditions of the permit and fees. Violation of the Policy or any specified or implied condition constitutes grounds for immediate revocation of the permit and equipment. Applicant agrees to report monthly readings by the 15th of every month via phone call or emailed picture to include the meter number and register dial showing usage. **Failure to report monthly readings will result in a \$500 penalty.** All commercial backflow assemblies must be tested yearly in accordance with Volume 2, Part C – Cross Connection Control Plan of the FCWSA Operating Code. Therefore, all hydrant meter rental units shall be returned to the FCWSA for renewal of the hydrant meter account and for annual backflow testing. Each yearly rental must be renewed within the month of the original rental period. Applicant agrees to relinquish the meter to FCWSA at any time.

Applicant Signature Date

Print Name

To be completed by FCWSA – Do not write under this line

Permit Number: _____

Deposit Received: _____

Inspection Fee Received: _____

Meter Number Issued: _____

Reading of Meter When Issued: _____

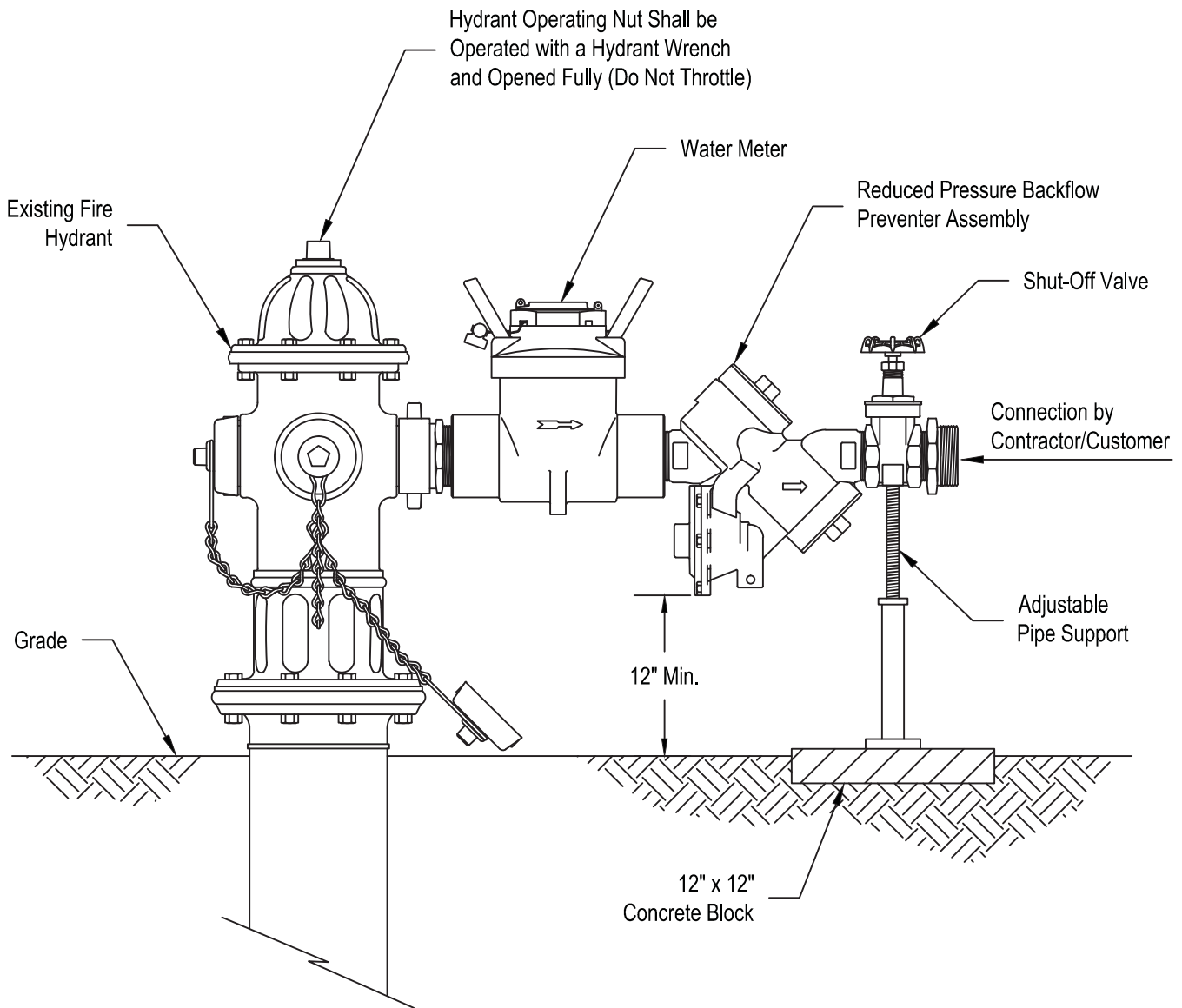

Notes:

1. Fire hydrant water use shall be permitted on a temporary basis where a permanent water connection is not available, subject to the terms and conditions established in Volume 2, Part A, Section 5.5 of the Authority's Operating Code.
2. Start with hydrant and shut-off valve closed. Slowly open the hydrant until the backflow preventer is completely pressurized. After the device has been pressurized, vent all trapped air from both check valves by slightly opening each of the four test cocks. Slowly open the downstream shut-off valve. The hydrant meter assembly is now in service. **Do not close valves on the assembly or discharge line quickly.**
3. Contractor/Customer shall protect the hydrant meter assembly from damage, theft, and misuse.
4. Contractor/Customer is held responsible for any damage to the fire hydrant and infrastructure due to improper use.
5. Broken or damaged hydrant meter assemblies must be reported to the Authority immediately.
6. Contractor/Customer is responsible for any and all water consumption.

WM-05



Fauquier County
Water and Sanitation Authority

Temporary Hydrant Meter Assembly

Not to Scale

Revised: 11/28/17

Volume 2 Part A Section 5.5 – Public Fire Hydrants

5.5 Public Fire Hydrants

- A. Indemnification - The Authority does not guarantee fire flow in its systems and shall not be responsible for, nor considered in any manner to be an insurer of persons or property against injury, loss or damage by fire, water, failure to supply water or pressure, or any other cause whatsoever.

- B. Restrictions - Except as provided in 5.5.C. below, water from any public fire hydrant shall not be used for construction purposes, sprinkling streets, flushing sewers or gutters, or for any purpose other than the fighting of fires by County authorized units, unless specifically permitted by the Authority for a particular circumstance. Upon written request, the Authority may install supplemental public fire hydrants at the sole expense of any interested person.

- C. Use – Except for authorized emergency service personnel, all fire hydrant water use shall be permitted on a temporary basis where a permanent water connection is not available, subject to the terms and conditions established in this Section 5.5. Any use of fire hydrants hereunder shall be subject to a permit and the permit may be revoked at any time by the Authority where the public health, safety and welfare may be jeopardized.

- D. Application – Any person seeking the use of water from any fire hydrant must submit an application to the Authority on the forms established by the Authority from time to time.

- E. Installation and Operation - Upon approval of the application for temporary use of a fire hydrant, the Authority shall issue a Hydrant Meter Permit to the applicant, the “Permit Holder”. The Hydrant Meter Permit shall be specific to the applied for fire hydrant only. Water shall be delivered through an approved hydrant meter which complies with the Authority’s Utilities Standards Manual. All hydrant meters shall be installed and removed by the personnel of the Authority.

- F. Operation of Hydrant Meter - All valves used to isolate the hydrant for installation and removal shall be operated by the Authority’s personnel. The Permit Holder shall be responsible for any damage to the hydrant, the hydrant meter or any associated infrastructure due to improper use of the hydrant. Meters shall not be tampered with in any way and any attempt to divert service through an unauthorized connection shall be grounds for revocation of the Hydrant Meter Permit. The revocation of any permit shall be the basis of denial of any future Hydrant Meter Permit request by the Permit Holder. Broken or damaged meters must be reported to and returned to the Authority immediately. The Permit Holder shall be responsible for all costs of any necessary repairs to the meter, which shall be paid prior to its reinstallation. All hydrant meters shall be affixed with an inspection tag for the calendar year which shall not be tampered with or removed by the Permit Holder. Any tampering with the tag or the hydrant meter shall be grounds for the immediate termination of the permit.

- G. Meter Readings - Hydrant meter readings shall be made monthly at the request of the Permit Holder. A failure to report monthly readings shall result in the forfeiture of the Hydrant Meter Permit and any sums held as Meter Deposit for the hydrant meter. All meter readings shall be done by the Authority's personnel.

- H. Fees and Charges - All permitted fire hydrant meters shall be subject to the payment of fees, charges and deposits shown in Section 2.3.1 of Volume 2, Part B of this Operating Code.

Volume 2 Part B Section 2.30 – Hydrant Meter Fees

2.30 Hydrant Meter Fees

- A. Meter Deposit: \$2,000

- B. Monthly Rates: Hydrant Meters are billed the same rates as domestic water meters

- C. Miscellaneous Charges:
 - 1. Inspection Fee - \$20.00
 - 2. Failure to report monthly reading - \$500.00
 - 3. Unauthorized use charge - \$250.00
 - 4. Late payment fee is the same as the Authority's domestic customer accounts